

November 5, 2021

## PRODUCT CHANGE NOTIFICATION

This letter is to inform you of product changes in our product line, effective immediately:

### PRODUCTS IMPACTED:

- 1.5" and smaller Male Threaded Mounting Plates with standard threads (MM Series).

### DESCRIPTION OF THE CHANGE:

- The flange diameter of Kocher's **1.5" and smaller male threaded mounting plates with standard threads has been reduced**, as follows:
  - All sizes 1.5" and below originally had a 2.25" flange diameter.
  - Now 1.5" plates will have a 2" flange diameter, and 1" & below plates will have a 1.5" flange diameter.

Please, refer to the example below illustrating modification in the 1" NH M MOUNTING PLATE (part number MM101):

**FORMER DESIGN**

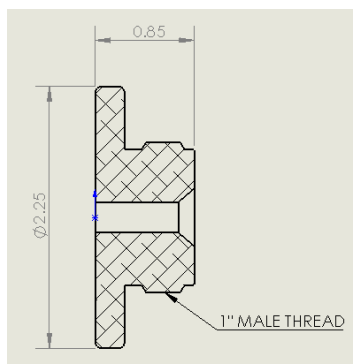

**NEW DESIGN**

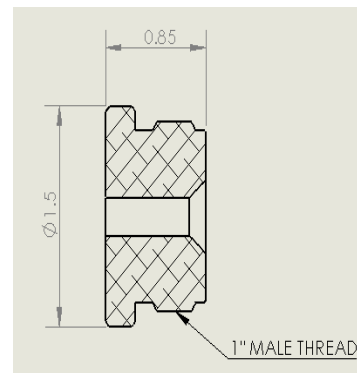

- Exception: this modification does not impact the 1.5" mounting plates with special threads, including FDNY.

### IMPLEMENTATION DATE:



75 Highland Drive  
Putnam, CT 06260  
T 860.963.3377  
F 860.963.3385

- The change will be effective immediately and implemented in a rolling basis.

**CUSTOMER IMPACT:**

- There is no impact to fit and function of the products changed.
- The change does not apply for female mounting plates (MF series).
- The current product orders already acknowledge in the system could be impacted.
- There is no change in the quality standards or product warranty.

Should you have any questions regarding this change notice or need additional information, please contact your regional sales representative or the Kochek Customer Service at 860-963-3377, [sales@kochek.com](mailto:sales@kochek.com)

Sincerely,

Product Team  
KOCHER Co, LLC