

# Dual-Purpose Floating Barrel Strainers

Kochek's self-leveling dual-purpose floating barrel strainer is a 2-in-1 unit that can be rapidly deployed as either a floating strainer or a barrel strainer, expanding drafting flexibility while saving space on your apparatus. Barrel strainer detaches from float in seconds, for situations where a barrel strainer is needed. These versatile strainers are ideal for both natural water sources and portable tanks. Available with a wide variety of connection types to suit most rural firefighting applications.

**Strainers meet or exceed applicable NFPA requirements.**

U.S. Patent 7794589

## Main Features

- Available with 2-1/2" - 8" diameter hose connections
- Big Water models combine popular 6" connections with oversized 8" strainers
  - This combination delivers reduced friction loss & maximum flow rates
- Optional foot valve available upon request
  - 2-1/2" - 3" Sizes - Poppet type with spring-loaded metal valve disk
  - 4" - 8" Sizes - Membrane type with flexible rubber valve disk
- High performance design - lightweight, durable & compact
- Optimized for use with Kochek's lightweight PVC suction hose
- Vortex Shield engineered to protect against whirlpooling
- Self-leveling full time swivel automatically keeps product upright
- Tethered rocker lug cap secures strainer to float
  - Quick & easy to remove by hand, or with spanner
- Rope hook included on barrel strainer for added control

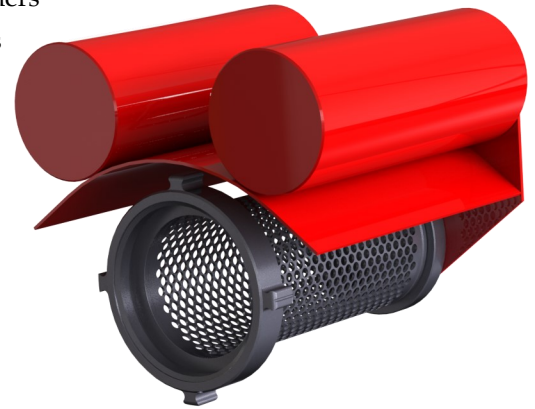

FBSD60—Fully Assembled  
(For Floating Strainer Applications)

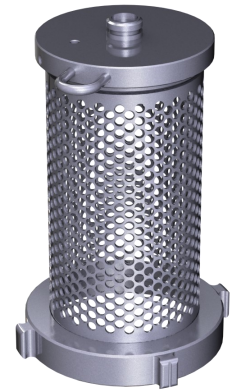

FBSD60—Separated  
(For Barrel Strainer Applications)

## Hose Connections

- Available with 2-1/2" - 8" NH threads, storz, or camlock connections
- Special threads available upon request

## Finishes & Colors

- Standard - Powdercoat red & silver, or powdercoat red & silver with black storz
- Other non-standard powdercoat colors available upon request
- Chrome, hardcoat, anodize, and k-brite finishes optional, available on barrel strainer only



Standard Barrel Strainer

+



Standard Floating Strainer

=



Dual-Purpose Strainer

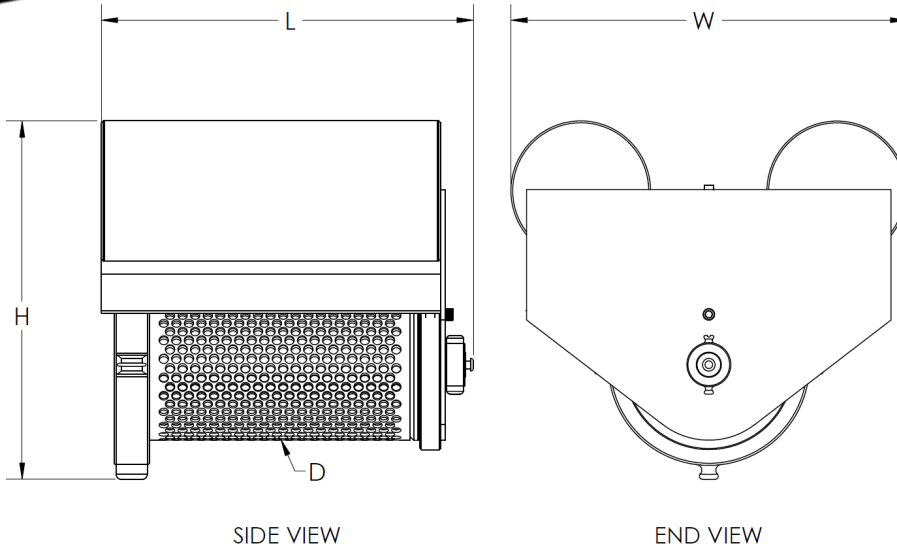

### OVERALL DIMENSIONS

Size Inches	Part Number (NH Female)	Length* L	Width W	Height H	Strainer Ø D
2.5"	FBSD25-P07-P09	12-1/2"	12"	9"	4"
3"	FBSD30-P07-P09	12-1/2"	12"	9"	4"
4"	FBSD40-P07-P09	13"	14"	13"	5-1/2"
4.5"	FBSD45-P07-P09	13"	14"	13"	5-1/2"
5"	FBSD50-P07-P09	13"	14"	13"	5-1/2"
6"	FBSD60-P07-P09	15"	16"	14-1/2"	6"
6" Big Water	FBSD602-P07-P09	15"	16"	14-1/2"	8"
8"	FBSD80-P07-P09	15"	21"	19"	8"

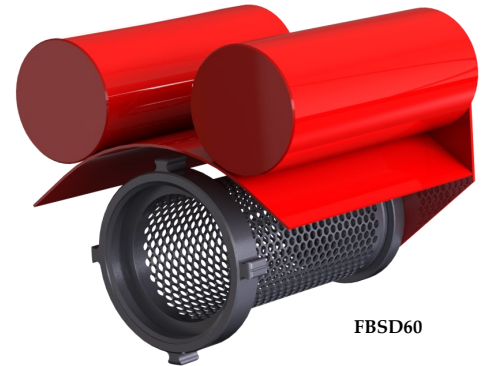

(\*) Storz and Camlock configurations will be longer than NH, but similar in width and height. Optional Foot Valve may also add length, depending on size and type.

### MOST POPULAR SIZES & CONFIGURATIONS

Size Inches	Part Number** (NH Female)	Part Number** (Storz)	Part Number** (Camlock Female)
2.5"	FBSD25-P07-P09	FBSD257-P07-P09-P18	FBSD254-P07-P09
3"	FBSD30-P07-P09	FBSD307-P07-P09-P18	FBSD304-P07-P09
4"	FBSD40-P07-P09	FBSD407-P07-P09-P18	FBSD404-P07-P09
4.5"	FBSD45-P07-P09	FBSD457-P07-P09-P18	FBSD454-P07-P09
5"	FBSD50-P07-P09	FBSD507-P07-P09-P18	FBSD504-P07-P09
6"	FBSD60-P07-P09	FBSD607-P07-P09-P18	FBSD604-P07-P09
6" Big Water	FBSD602-P07-P09	FBSD6027-P07-P09-P18	FBSD6024-P07-P09
8"	FBSD80-P07-P09	FBSD807-P07-P09-P18	FBSD804-P07-P09

(\*\*) To specify an optional Foot Valve, add "FV" to the base part number. Example: FBSD25FV-P07-P09

### Customizations

- Laser engraving is available.
- Other non-standard sizes, finishes, colors, and special threads are available upon request.
- Minimum quantities and additional fees may apply.